

◎ INJECTION PRESS RANGE: 2500-5000 TON ◎

Digital AC SERVO Robot Series

TW-2500FMIV

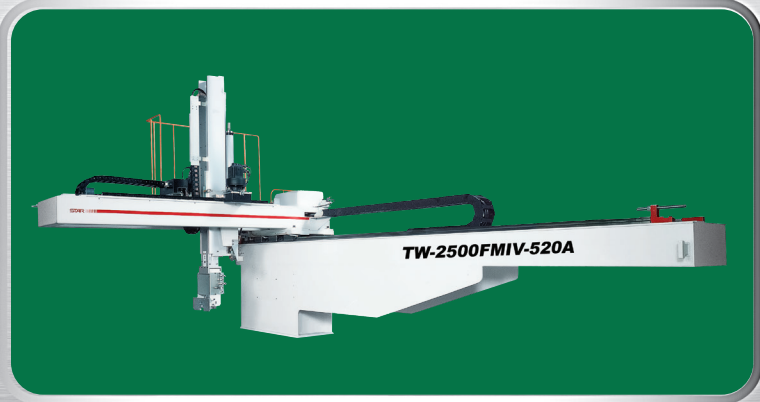

COMMON SPECIFICATIONS

| Power Source | Air Pressure | Drive | Posture (air cylinder) | Recommended Max Load | Posture Torque @ 70 PSI | Control Types |
|---------------------|------------------|----------------|------------------------|----------------------|-------------------------|---------------|
| 200 VAC ± 10% 60 Hz | 70 psi (.48 MPa) | AC Servo Motor | 90° | 176 lbs (80 kg) | 40.6 ft-lbs (55.0 N•m) | STEC-520A |

GENERAL SPECIFICATIONS

| Model | Stroke | | | | Electric Consumption (kVA) | Max Power Consumption (kW) | Main Body Weight (KG) | Air Consumption (ft ³) |
|-------------|------------------|------------------|------------------|-------------------|----------------------------|----------------------------|-----------------------|------------------------------------|
| | (P) Vertical | (R) Vertical | Crosswise | Traverse | | | | |
| TW-2500FMIV | 98.43" (2500 mm) | 98.43" (2500 mm) | 78.74" (2000 mm) | 157.48" (4000 mm) | 15.5 | 7.9 | 1212 (2672 lbs) | 0.67 (18.9 NI / Cycle) |

STANDARD FEATURE

| |
|---|
| Vacuum Generator with Part Present Sensor |
| Part Grip Circuit |
| Sprue Grip Circuit |
| USB Port |
| Ethernet Port |
| Sample and Chuck Change Positons |
| Product Packaging (256 each axis) |
| CNC Step Programming |
| Micro SD Card |
| CPC® and AMP® Connections at the Head |
| Active Vibration Control |
| IMM Mounting Weldment |
| Multi- Level Password Protection |
| Position, Speed and Timer Adjust in Auto |
| Alarm History |
| Grease Pocket LM Bearings |

OPTION LIST

| |
|--|
| Additional Vacuum Generator with Part Present Sensor |
| Additional Part Grip |
| Nipper on Chuck |
| Rotation 90°, 180° 2-Position, 180° 3-Position |
| Shuttle on Tool |
| Mold Spray |
| Air Blow |
| 1-3 Color Alarm Light |
| Special Paint |
| Free Packaging |
| Central Lube |
| Quick Chuck Change |
| Servo Posture Rotate |

ISO 9001 Certified
Quality Management
System

OVERALL DIMENSIONS

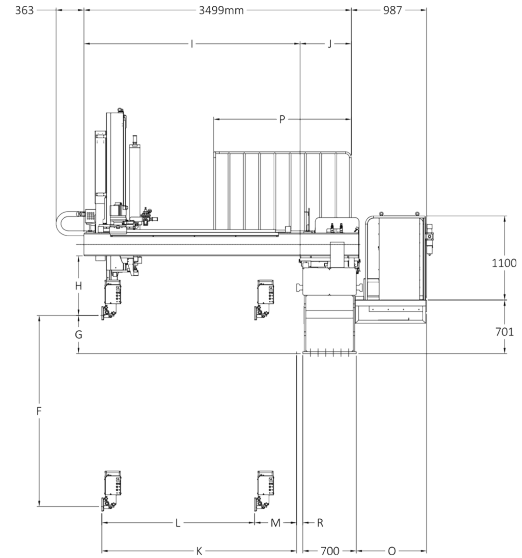
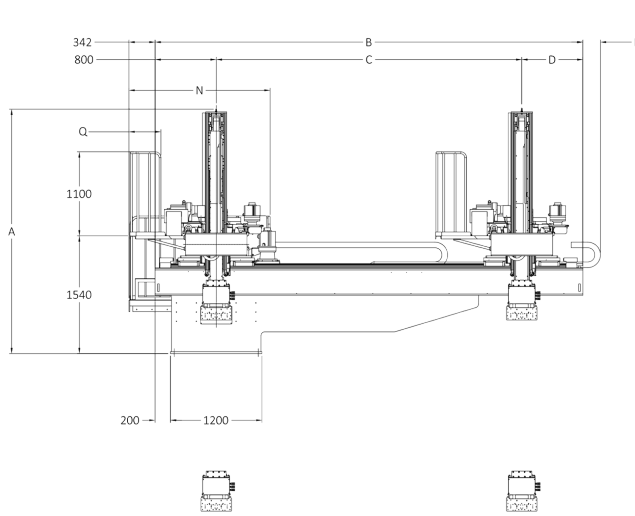

TW-2500FMIV

| | | TW-2500FMIV |
|---|--|------------------|
| A | Overall Height | 125.91" (3198mm) |
| B | Overall Width | 220.47" (5600mm) |
| C | Traverse Stroke | 157.48" (4000mm) |
| D | Overhang, Release Side | 31.50" (800mm) |
| E | Cable Guide Overhang | 9.02" (229mm) |
| F | (P) Vertical Stroke | 98.43" (2500mm) |
| G | (P) Vertical Standby | 19.69" (500mm) |
| H | Bottom of Crosswise to Chuck Mount Postion | 30.63" (778mm) |
| I | Crosswise Arm | 111.42" (2830mm) |
| J | Thickness | 26.34" (669mm) |
| K | Crosswise Reach Max. | 100.39" (2550mm) |
| L | Crosswise Stroke Max. | 78.74" (2000mm) |
| M | Crosswise Standby Min. | 21.65" (550mm) |
| N | Platform at Rail Side Length | 72.72" (1847mm) |
| O | Platform at Rail Side Width | 36.26" (921mm) |
| P | Platform at Carriage Unit Side Length | 70.87" (1800mm) |
| Q | Platform at Carriage Unit Side Width | 16.50" (419mm) |
| R | Base Offset | 3.15" (80mm) |



Wisconsin (HQ)
 N90 W14401 Commerce Drive
 Menomonee Falls, WI 53051
 Phone: 262-253-3550
 Fax: 262-253-3559
 Email: kscheife@starautomation.com

California
 18141 Beach Blvd. Unit 195
 Huntington Beach, CA 92648
 Phone: 714-375-2400
 Fax: 714-375-2446
 Email: ryamasaki@starautomation.com

Georgia
 5555 Oakbrook Parkway Suite 320
 Norcross, GA 30093
 Phone: 770-582-9350
 Fax: 770-582-9351
 Email: chebert@starautomation.com

Michigan
 17197 North Laurel Park Dr. Suite 125
 Livonia, MI 48152
 Phone: 734-462-9522
 Fax: 734-462-9527
 Email: jpoegel@starautomation.com

Indiana
 5625 Vogel Road Unit B
 Evansville, IN 47715
 Phone: 812-475-9947
 Fax: 812-475-9949
 Email: sberry@starautomation.com

Rhode Island
 860A Waterman Avenue
 E Providence, RI 02914
 Phone: 401-434-0617
 Fax: 401-434-0627
 Email: pgerzevitz@starautomation.com

Tennessee
 Sales Phone: 678-428-4202
 Service Phone: 615-796-5670
 Email: chebert@starautomation.com

Texas
 Phone: 262-853-6874
 Email: disken@starautomation.com

Star Seiki Mexico S.A. De C.V.
 Blvd Bernardo Quintana #7001
 Torre II Oficina 1004 Colonia Centro
 Sur, Queretaro, CP. 76090 Mexico
 Phone: +52-442-199-5180
 Email: knomura@starseikimexico.com