

◎ INJECTION PRESS RANGE: 500-1300 TON ◎

Digital AC SERVO Robot Series

MHY-1500VII

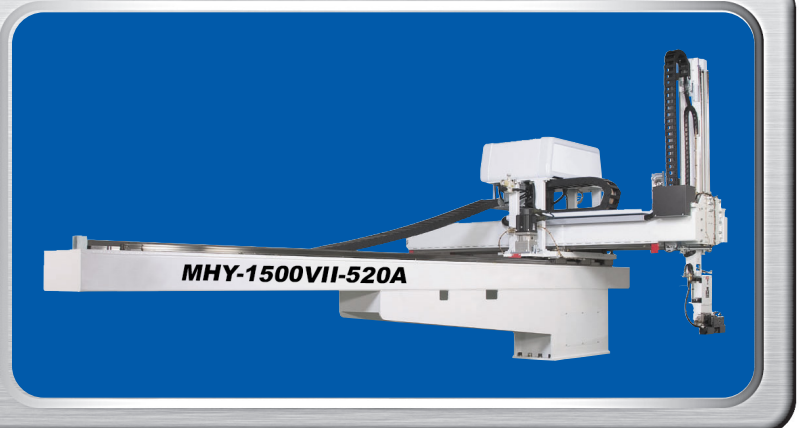

COMMON SPECIFICATIONS

Power Source	Air Pressure	Drive	Posture (air cylinder)	Recommended Max Load	Posture Torque @ 70 PSI	Control Types
200 VAC ± 10% 60 Hz	70 psi (.48 MPa)	AC Servo Motor	90°	77 lbs (35 kg)	81.10 ft-lbs (110 N·m)	STEC-520A

GENERAL SPECIFICATIONS

Model	Stroke				Electric Consumption (kVA)	Max Power Consumption (kW)	Main Body Weight (KG)	Air Consumption (ft ³)
	(P) Vertical	(R) Vertical	Crosswise	Traverse				
MHY-1500VII	59.06" (1500 mm)	N/A	62.60" (1590 mm)	98.43" (2500 mm)	11.0	5.6	1,247 (2749 lbs)	1.96 (55.4 NI / Cycle)

STANDARD FEATURE

Vacuum Generator with Part Present Sensor
Part Grip Circuit
Sprue Grip Circuit
USB Port
Ethernet Port
Sample and Chuck Change Positons
Product Packaging (256 each axis)
CNC Step Programming
Micro SD Card
CPC® and AMP® Connections at the Head
Active Vibration Control
IMM Mounting Weldment
Multi- Level Password Protection
Position, Speed and Timer Adjust in Auto
Alarm History
Grease Pocket LM Bearings

OPTION LIST

Additional Vacuum Generator with Part Present Sensor
Additional Part Grip
Nipper on Chuck
Rotation 90°, 180° 2-Position, 180° 3-Position
Shuttle on Tool
Mold Spray
Air Blow
1-3 Color Alarm Light
Special Paint
Free Packaging
Central Lube
Quick Chuck Change
Servo Posture Wrist

ISO 9001 Certified
Quality Management
System

OVERALL DIMENSIONS

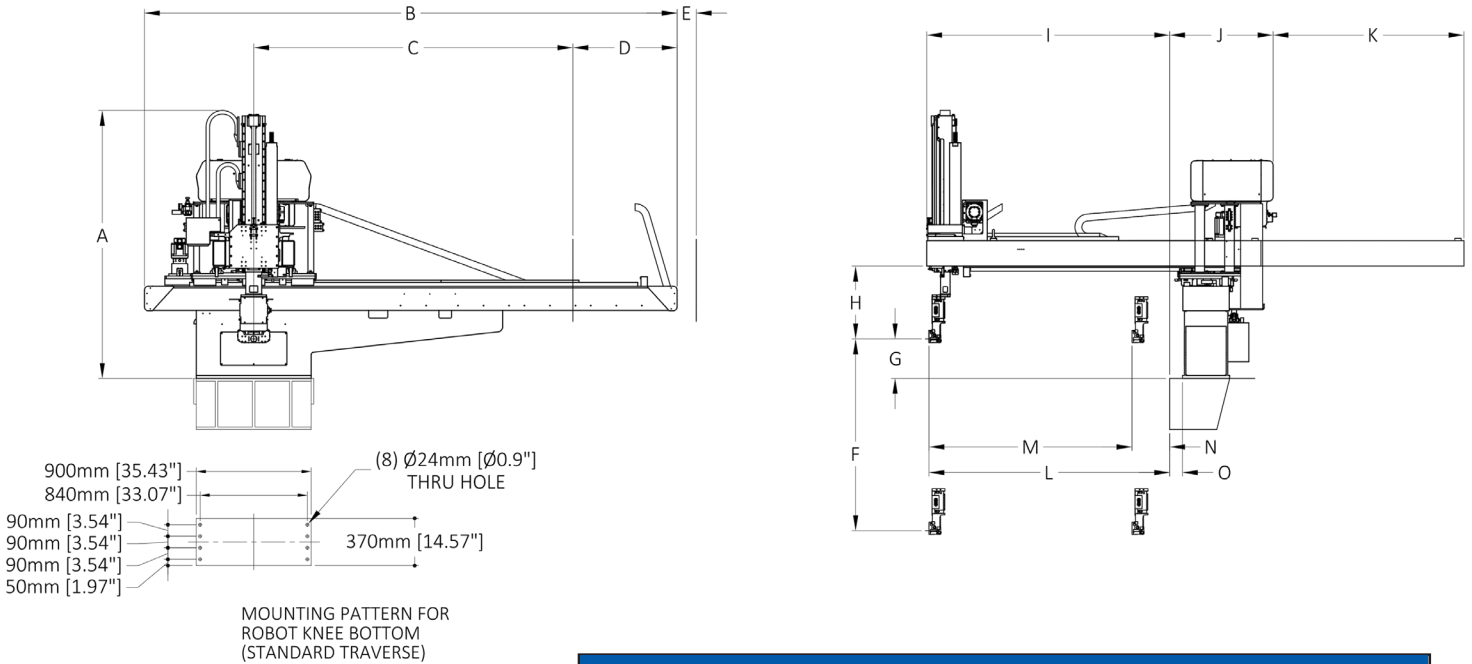

		MHY-1500VII
A	Overall Height	82.48" (2095mm)
B	Overall Width	164.25" (4172mm)
C	Traverse Stroke	98.43" (2500mm)
D	Overhang, Release Side	32.12" (816mm)
E	Cable Guide Overhang	0
F	Vertical Stroke	59.06" (1500mm)
G	Vertical Standby	12.17" (309mm)
H	Bottom of Crosswise to Chuck Mount Postion	22.40" (569mm)
I	Mold Mounting Face - Crosswise Arm End	74.92" (1903mm)
J	Mold Mounting Face to Box End	31.89" (810mm)
K	Retracted Crosswise Arm	58.86" (1495mm)
L	Crosswise Reach Max.	74.21" (1885mm)
M	Crosswise Stroke Max.	62.60" (1590mm)
N	Crosswise Standby Min.	11.61" (295mm)
O	Base Offset	3.93" (100mm)



Wisconsin (HQ)
N90 W14401 Commerce Drive
Menomonee Falls, WI 53051
Phone: 262-253-3550
Fax: 262-253-3559
Email: kscheife@starautomation.com

California
18141 Beach Blvd. Unit 195
Huntington Beach, CA 92648
Phone: 714-375-2400
Fax: 714-375-2446
Email: ryamasaki@starautomation.com

Georgia
5555 Oakbrook Parkway Suite 320
Norcross, GA 30093
Phone: 770-582-9350
Fax: 770-582-9351
Email: chebert@starautomation.com

Michigan
17197 North Laurel Park Dr. Suite 125
Livonia, MI 48152
Phone: 734-462-9522
Fax: 734-462-9527
Email: jpoegel@starautomation.com

Indiana
5625 Vogel Road Unit B
Evansville, IN 47715
Phone: 812-475-9947
Fax: 812-475-9949
Email: sberry@starautomation.com

Rhode Island
860A Waterman Avenue
E Providence, RI 02914
Phone: 401-434-0617
Fax: 401-434-0627
Email: pgerzevitz@starautomation.com

Tennessee
Sales Phone: 678-428-4202
Service Phone: 615-796-5670
Email: chebert@starautomation.com

Texas
Phone: 262-853-6874
Email: disken@starautomation.com

Star Seiki Mexico S.A. De C.V.
Blvd Bernardo Quintana #7001
Torre II Oficina 1004 Colonia Centro
Sur, Queretaro, CP. 76090 Mexico
Phone: +52-442-199-5180
Email: knomura@starseikimexico.com