

Injection Press Range
2200~5000
ton

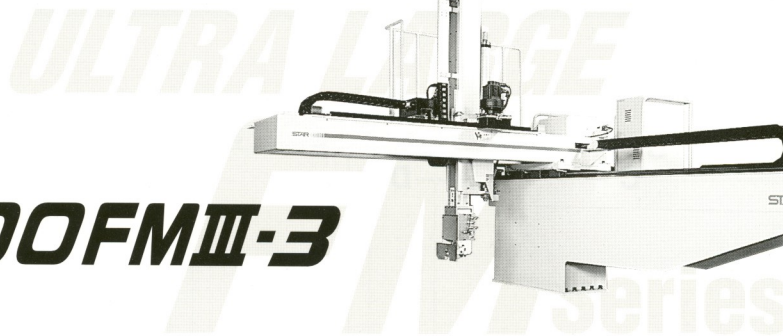

TW-2500FMⅢ-3

COMMON SPECIFICATIONS

POWER SOURCE	AIR PRESSURE	DRIVE SYSTEM	POSTURE (AIR CYLINDER)	AIR CYLINDER DRIVING FORCE (Air Pressure at 0.49 MPa)		STANDARD CONTROL BOX
				MAX. LOAD, INCL. CHUCK WEIGHT	POSTURE TORQUE	
AC200 ±10% 50/60Hz	0.49MPa (5kgf/cm ²)	AC SERVO MOTOR IM SERVO MOTOR AIR CYLINDER	90° FIXED	80kg	123.0N·m [12.55kgf·m]	STEC-450

GENERAL SPECIFICATIONS

MODEL	Electric Consumption (kVA)	Stroke			Accuracy of Movement (mm)	Net Weight (kg)		Dry cycle (sec / cycle)		Air Consumption (N ₂ / cycle)
		Vertical(mm) (AC Servo)	Crosswise(mm) (AC Servo)	Traverse(mm) (IM Servo)		Main Body	Control Box	Extract Dry cycle	ALL Dry cycle	
TW-2500FMⅢ-3	12.6	2500 (3200)	550~2550	4000 (4500)	Vertical / Crosswise ±0.2 Traverse ±0.8	4100	75	4.2	26.5	200

● Figures in () show option strokes. ※ Dry cycle is for L-shaped movement. All timers set at 0 and no ejector timer used.

OPTION LIST

OPTION	MODEL	CODE NO.	FM TYPE		Remarks
			STEC-450(STANDARD)		
Product Extract Side	Extraction from fixed mold	0014-03	○		
	Vacuum generator with sensing unit	0007-05	○		
	Mold release spray circuit	0013-02	○		Excluding Auto-Ben itself
	Air blow circuit	0019-01-02	○		For mold or product
	Extract circuit for under-cut mold	0016-01	○		
	Product rotation	0025-01-02-03	○		Select from 90 fixed, within mold, outside mold or release side
	Vertical Arm descent standby at product extract side	0054-01	○		
	Mold close during arm ascent	0055-01	○		Please consult with our sales person.
Traverse	Defective product reject circuit	0018-01	○		Available with an output signal from IMM.
	Hinge circuit	0075-01	○		
	Delayed traverse	0026-01	○		
Product Release Side	Air nipper in chuck	0008-01	○		
	Positioning 1~99		○		Each axis (traverse, vertical and crosswise)
	Horizontal rotation	0025-05	○		
	Release products at two different points	0001-01	○		
Others	Floppy disk drive for external memory		○		
	I.M.M. Link operation	0032-05	○		RS232C, Relay Contact.
	Centralized lubrication unit w/Manual pump	0084-02	○		
Centralized lubrication unit w/Auto pump	0084-03	○			

● ○: built in standard function ○: possible adopt ● Some combinations of options may not be available due to excess of controller's capacity.

OUTER DIMENSIONS

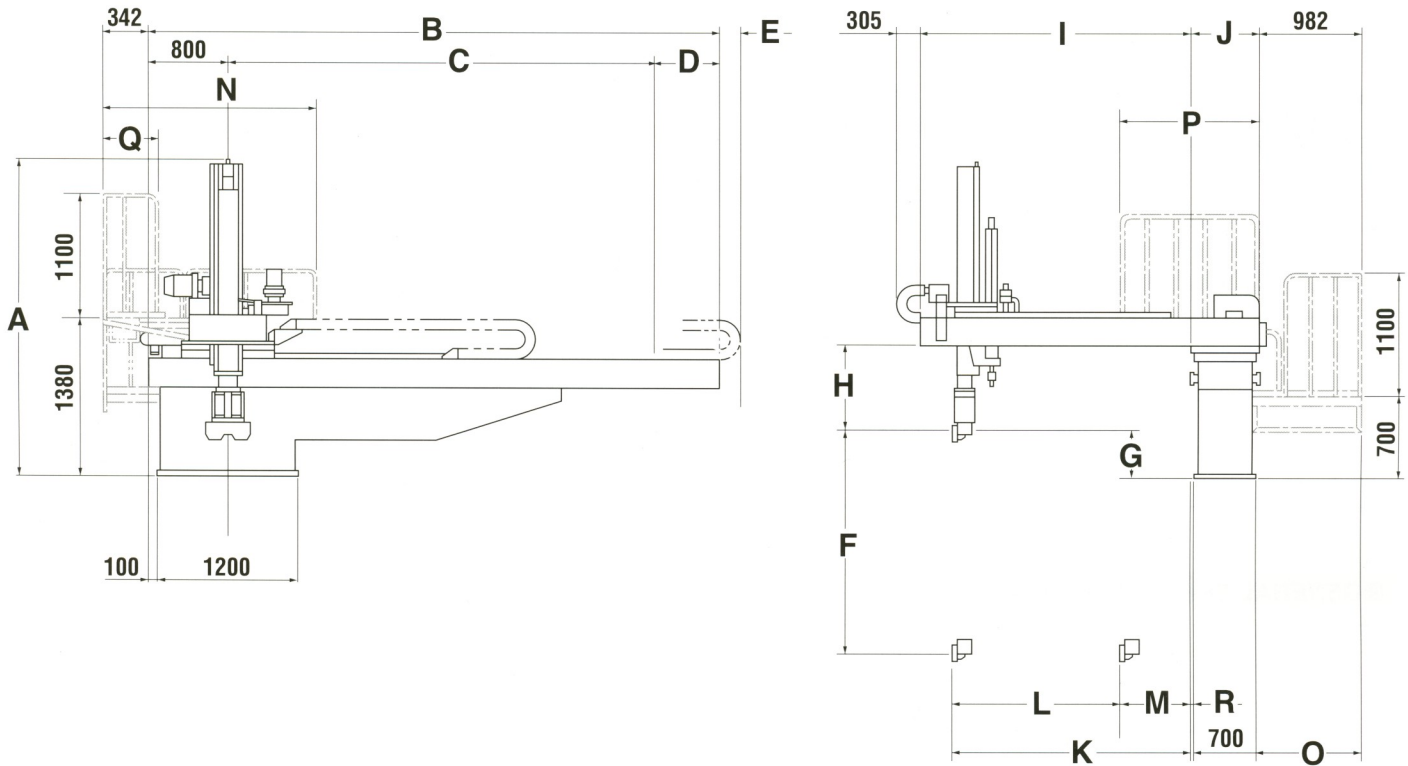

OUTER DIMENSIONS

(mm)

MODEL	A	B	C	D	E	F	G	H	I	J	K	L	M	N	O	P	Q	R
	Overall height	Overall width	Traverse stroke	Overhang, release side	Cable guide Overhang	Vertical stroke	Vertical standby	Bottom of crosswise to chuck mount position	Crosswise arm	Thickness	Crosswise reach max.	Crosswise stroke max.	Crosswise standby min.	Platform at rail side length	Platform at rail side width	Platform at carriage unit side length	Platform at carriage unit side width	Base offset
TW-2500FM III-3	3197	5600	4000	800	178	2500	500	778	2830	700	2550	2000	550	1847	1017	1505	460	80

- Thickness of posture area is basically about 254mm(depends on tubing).
- In case Product rotation is attached, dimension of "G" is 389mm and thickness of posture area is 254mm.
- W/o ladder for platform at railside.

● All stated here is subject to change without advance notice.



STAR SEIKI CO., LTD.

Head Office / International Division: 3-133, Akita, Ohguchi-cho, Niwa-gun, Aichi Pref., 480-0132, JAPAN PHONE:0587-95-7572 FAX:0587-95-7573

for more information
www.starseiki.com

- U.S.A. **STAR AUTOMATION, INC.** N90, W14401, Commerce Drive, Menomonee Falls, WI 53051, U.S.A. PHONE:262-253-3550 FAX:262-253-3559
- Singapore **STAR SEIKI SINGAPORE PTE. LTD.** 900 South Woodlands Drive #05-07, Woodlands Civic Centre, Singapore 730900 PHONE:6219-1348/7 FAX:6219-1349
- Taiwan **STAR SEIKI TAIWAN, INC.** 7F, No.120, Chung Cheng Rd., Shih Lin District, Taipei 11158, TAIWAN R.O.C. PHONE:02-2836-0039 FAX:02-2835-9987
- China **STAR SEIKI (HONGKONG) CO., LTD.** 12th Floor, CCT Telecom Building, No.11 Wo Shing Street, Fo Tan, Shatin, New Territories, HONG KONG P.R.C. PHONE:2687-6745 FAX:2690-4322
- China **STAR SEIKI (SHANGHAI) CO., LTD.** Room 1, 25F, BLOCK C 70, CAO BAO ROAD, 200235, SHANGHAI, P.R.C. PHONE:021-6432-6452 FAX:021-6432-6561
- Europe **STAR AUTOMATION EUROPE S.P.A.** Via Salgari 2R/2S, 30030, Caselle di S. Maria di Sala, Venice, ITALY PHONE:0041-57-85-311 FAX:0041-57-85-312
- Korea **YUDO-STAR AUTOMATION CO., LTD.** 104 Block, 3 Lot, 652-2 Gojan-Dong, Namdong-Gu, Inchun, 405-310, KOREA PHONE:032-450-4500 FAX:032-818-8111
- Malaysia **STAR SEIKI (SINGAPORE) PTE. LTD. K.L. BRANCH** 29-1A, Jalan Bandar-3, Pusat Bandar Puchong, 47100 Selangor, MALAYSIA PHONE:03-5882-0211 FAX:03-5882-0212
- Thailand **STAR SEIKI (THAILAND) CO., LTD.** 22 Soi Sukhumvit 3 (Nana Nua), Klongtoey Nua, Wattana, Bangkok 10110, THAILAND PHONE:02-651-0285 FAX:02-651-0288
- Brazil **STAR SEIKI BRASIL LTDA.** Rua Pio XI, 431, Ander Superior-CEP:05060-000 Lapa, SAO PAULO-SP-BRAZIL PHONE:011-3641-6131 FAX:011-3834-1756